

8A Bumper / Water Tank / Weight Rack System

For use with the 7000-Series, 8000-Series, and 9000-Series SPFH

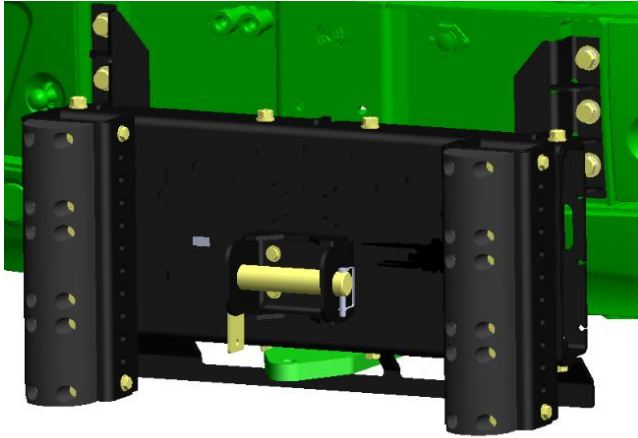

Base Bumper

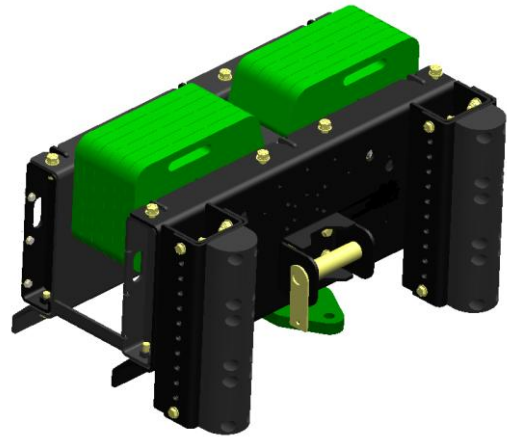

Weight Rack

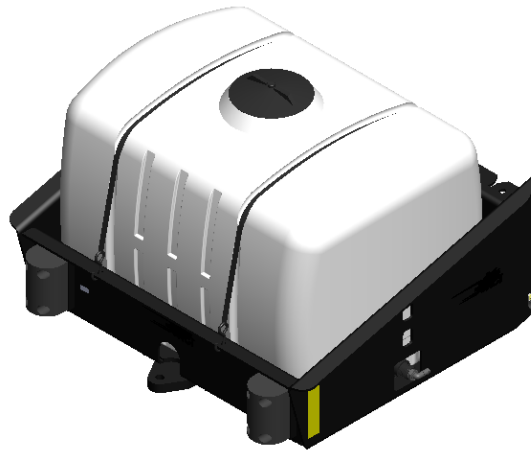

Water Tank (w/Tow Hitch)

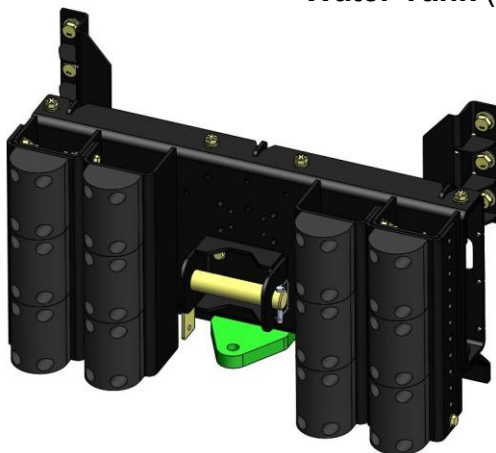

Inner Bumper Kit



Bolt-On Pintle Hitch and Receiver Hitch

The 8A Bumper Attachment and Accessories are available from RCI Engineering for the John Deere 7000-Series, 8000-Series, and 9000-Series Self-Propelled Forage Harvesters.

Intended Use:

The 8A is intended to be used to provide a bumper as well as ballast for the SPFH to allow for ease of installation of larger headers. Other options are provided for additional functionality and value of the Bumper Attachment System.

Options:

1. Base Bumper
2. Weight Rack
3. Water Tank (w/ Tow Hitch)
4. Inner Bumper Kit
5. Bolt-On Pintle Hitch
6. Bolt-On Receiver Tube

Base Bumper

The RC125061 Base Bumper Bundle is needed for all configurations and accessories offered for this system.

The bumper height is adjustable and allows for ground clearance from approximately 12" to 21", depending on tire options of the SPFH.

Clearance is provided for access to rear SCV and electrical connection of SPFH for auxiliary functions. A tow strap mount with removable pin at rear of unit is standard for ease of connection of tow straps and/or chains.

The original John Deere hitch plate can be mounted to the bottom of the rear bumper. Bumper frame is constructed of 3/8" thick steel and reinforced for the most demanding conditions.

Six standard rubber bumpers are included as standard equipment, and additional rubber bumpers can be added if desired with an additional bundle.

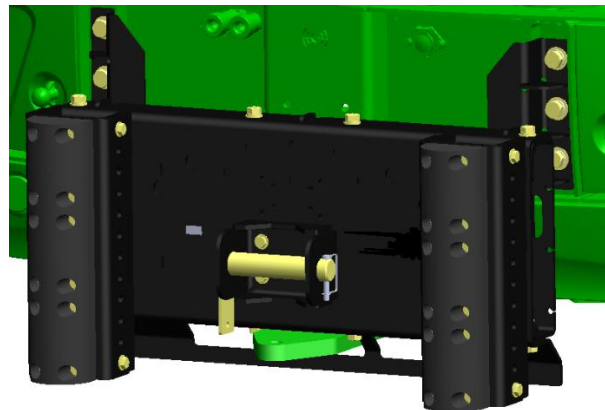

Weight Rack

The Weight Rack option allows for a more cost-effective ballast solution than factory weights and a custom-built bumper.

Machines can be ordered from the factory “Less Ballast” and standard John Deere tractor suitcase weights can be used with the Weight Rack.

A maximum of 12 suitcase weights (6 per side) can be used with the weight rack. Weights are retained with a threaded rod.

The modular design allows for removal of the weight rack and reinstallation of the bumper when using hay pickups to:

- Reduce compaction in hay fields to increase yield
- Improve fuel efficiency, especially in transport.
- Improve harvest capacity when the engine is under full load

When switching from hay pickups to corn heads, the weight rack can be easily removed using forklift pockets or with chains at the lift point locations on the rack.

The original John Deere hitch plate can be mounted to the bottom of the weight rack. The weight rack is used in conjunction with the Base Bumper. See 8A Operator Manual for more information regarding ballasting.

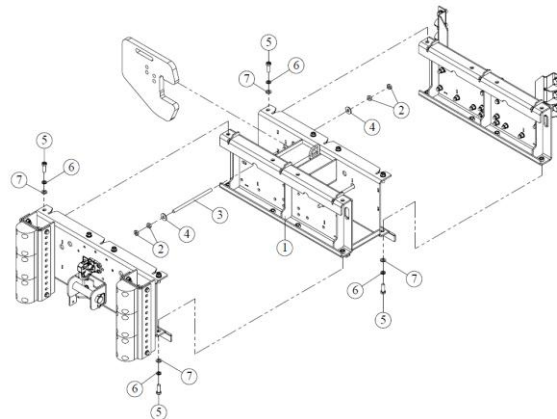
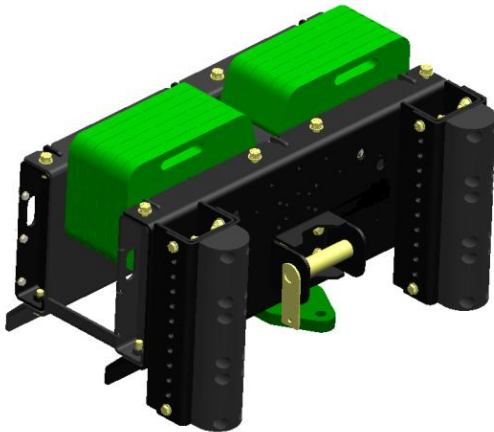

Water Tank (w/ Tow Hitch)

The optional water tank provides for 200 gallons of additional water carrying capacity and connects to the on-board water system for extended harvesting. A pulling hitch option is available for the Water Tank to add a point for a tow rope for in-line pulling with this option.

Two rubber bumpers are provided at the rear of the attachment for limited protection. The Water Tank attachment can be removed, and the bumper plate re-installed to provide additional protection for the back of the machine when not in use. The Base Bumper is needed for use with the Water Tank. The Water Tank is retrofittable to all previous 8A Bumper Attachments.

Hose and fittings are provided with the tank to connect to the SPFH on-board water system or customer's inoculant system, but end connections are the responsibility of the customer.

IMPORTANT: The Tow Hitch Kit option is not for use with trailers or other implements. It is provided for attachment of a chain, strap or rope and only in-line (i.e. no side-pulling).



Inner Bumper Kit

The optional Inner Bumper Kit provides for additional protection at the back of the SPFH for when tractors with narrow weight racks are used on wagons and carts when opening fields, or additional protection from trucks in corners and other tight conditions.

This bundle adds 6 additional rubber bumpers and is adjustable with the existing rubber bumpers. All parts are bolt-on and retrofittable to all previous 8A Bumpers.

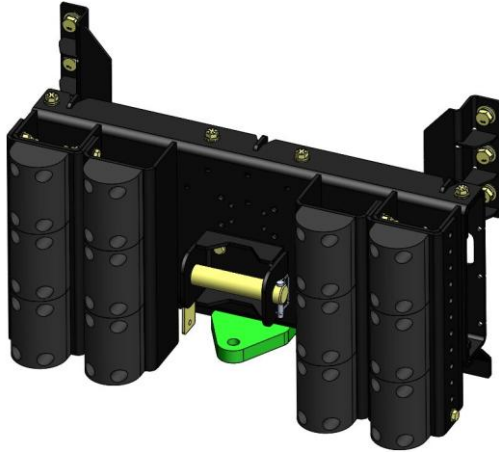

Bolt-On Pintle Hitch and Receiver Tube

The optional Bolt-On Pintle Hitch is provided for quick chain and strap attachment. It is NOT INTENDED to be used for pulling trailers. It bolts into existing holes in the 8A Bumper attachment.

The optional Bolt-On Receiver Hitch is provided for quick installation of customer accessories such as a pintle hitch or D-Ring on a 2-inch receiver. It is NOT INTENDED to be used for pulling trailers. It bolts into existing holes in the 8A Bumper attachment.

The Removable Tow Pin is included as standard on all 8A Bumper attachments.

These options will retrofit to all MY22 and newer 8A Bumper attachments.

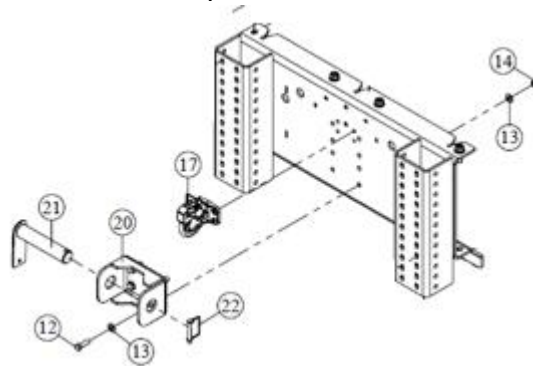

IMPORTANT: Straps, toolboxes, and any other accessories are not included in any bundle
SPFH Ballasting Recommendations for Weight Rack

IMPORTANT: Proper ballasting will keep efficiency of the four-wheel drive system and steering function when braking.

IMPORTANT: Always put the same number of weight plates inside the left and right side of weight carrier when using the Standard Weight Rack. Refer to SPFH Operator Manual for information regarding weight plate installation if a weight rack is not needed.



IMPORTANT: Do not overload rear tires, especially when the header is removed.

IMPORTANT: Special field conditions may require higher ballasting to keep efficiency of the four-wheel drive system and steering function.

Depending on machine/header type configurations, ballasting differs. To properly ballast the machine, ALWAYS refer to the relevant ballasting chart, then install required amount of weight.

Specifications – Base Weight:

RC125061	Bundle, 8000- and 9000-Series Base	583 lbs (265 kg)
RC125070	Bundle, 7000-Series Base	525 lbs (238 kg)
RC125049	Rack, Standard Weight	400 lbs (180 kg)
Combined Weight		Approx. 985 lbs (445 kg)
RC125100	Bundle, Water Tank (w/ base, water.)	Approx. 2,600 lbs (1180 kg)

Ordering Information:

RC125061	Bundle, 8000-and 9000-Series Base	Qty 1
RC125070	Bundle, 7000-Series Base	Qty 1
RC125049	Rack, Standard Weight	Qty 1
RC125100	Assembly, Water Tank Bumper	Qty 1
RC125108	Kit, Tow Hitch (w/Water Tank option only)	Qty 1
RC125111	Kit, Inner Bumper	Qty 1
RC125068	Hitch, Pintle	Qty 1
RC950663	Kit, 2" Bolt-On Receiver Tube	Qty 1

Estimated Installation Times:

Base Bundle Installation	1.5 hours
Weight Rack and Water Tank Initial Installation	1 hour
Field change between weight rack, tank, and bumper	0.5 hour

All times are dependent on the use of appropriate tools and technician experience. No modifications to the SPFH are required for the installation, only the removal of a few components at the rear mount plate.

About RCI Engineering:

Visit www.RCI.ag for more product information, ordering, and pictures of this bundle.

RCI Engineering LLC also offers an assortment of attachments for other John Deere hay and forage equipment to improve performance, increase efficiency and to increase machine capabilities in different crop and field conditions.



RCI Engineering LLC is a John Deere Allied Supplier. All product and spare parts sales are only available through your preferred John Deere Dealer. All John Deere Dealers are RCI Dealers.

Dealers order all products from RCI directly. All parts, service and warranty matters are handled by RCI. The warranty for these products is 1 year of parts and labor as outlined in the RCI Warranty Statement. Visit www.RCI.ag for more product information, ordering, and additional information.

RCI Engineering LLC
208 River Knoll Drive
Mayville, WI 53050
info@RCI.ag

P: 920-387-9804
P: 888-472-4552 (Toll Free)
F: 920-387-9806
www.RCI.ag